



Stainless Steel Relief Valves Dome Top - Screwed or Flanged Connections

GRESSWELL G36 RELIEF VALVES

Side Outlet discharge with leak proof Dome Cover over the adjusting screw. These valves are commonly used for preventing a safe pressure being exceeded in pressurised systems.

The lift is proportional to the system overpressure.

Available with PTFE, viton and silicon soft seats.

SIZE RANGE

DN	15	20	25	40	50
in	½"	¾"	1"	1½"	2"

PIPE CONNECTIONS

INLET: Threaded 'G' (BSP) Male
to BS EN ISO 228/BS 2779

OUTLET: Threaded 'Rp' Parallel Female
to BS 21/BS EN 10226/ISO 7

Alternative thread standards, e.g. 'R' x 'Rc' (BSPT) or ANSI B1.20.1 (NPT) are available upon request.

FLANGED: Most flange standards can be accommodated, e.g. BS EN 1759 (Class designated), BS EN 1092 (PN designated) or BS 10 (Table designated) - please specify.

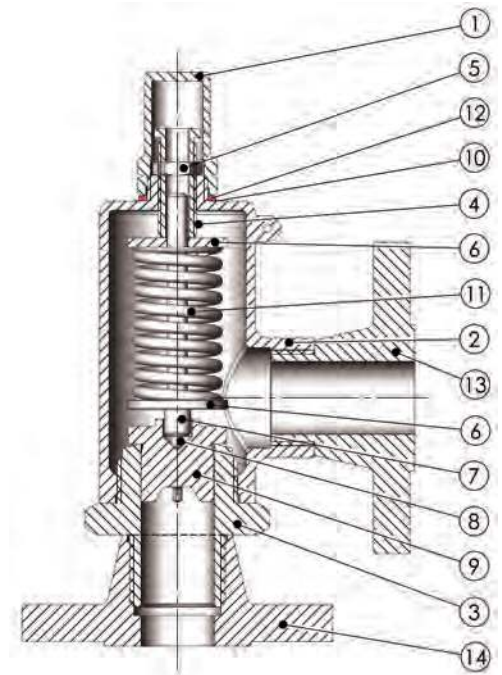

STANDARD SPECIFICATION

No.	Component	Material	No.	Component	Material
1	Dome Top	St. Steel AISI 316 (DIN 1.4401)	6	Spring Plate	St. Steel AISI 316 (DIN 1.4401)
2	Body	St. Steel ASTM A351/A351M CF8M	7	Spindle	St. Steel AISI 316 (DIN 1.4401)
3	Base	St. Steel ASTM A351/A351M CF8M	8	Ball	St. Steel AISI 420
3P	PTFE Seat	Virgin PTFE	9	Valve	St. Steel ASTM A351/A351M CF8M
3V	Viton Seat	Viton 85 Brown	10	Label	Metallised Polymer
3S	Silicone Seat	Silicone 50 Blue	11	Spring	St. Steel BS2056 302 S26
4	Adjusting Screw	St. Steel AISI 316 (DIN 1.4401)	12	Washer	PTFE
5	Lock Nut	St. Steel AISI 316 (DIN 1.4401)	13/14	Flanges (optional)	St. Steel AISI 316L (DIN 1.4404)

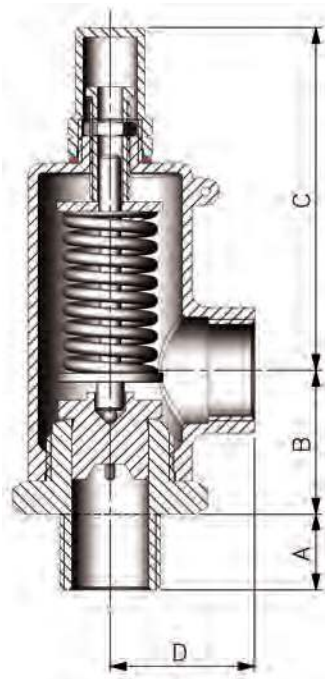

FEATURES & BENEFITS

Gresswell Valves are quality assurance approved to BS EN ISO 9001: 2008. Certificate No. 0910407.

Manufactured in accordance with BS 6759 Parts 1, 2 & 3 and compliant with BS EN ISO 4126 Part 1 with full Cat IV PED approval.

Only 4 springs are needed to cover the full pressure range.

Clear operating and maintenance instructions are supplied with each despatch.

Screwed/Flanged or a combination of both are available as standard.

See leaflet Ref: DC G36 for Discharge Capacities.

TESTING

All Gresswell Relief Valves are given a hydraulic seat tightness test before leaving the factory and the adjustment range is clearly marked.

All valves are supplied pre-set.

Flanged valves are pressure tested to ensure soundness of joints.

Special tests or witness testing can be arranged at extra cost.

DIMENSION CHART

Size	A	B	C	D	Weight (kg)
DN15	17	35	87	33	0.6
DN20	14	36	97	40	0.8
DN25	25	47	113	48	1.5
DN40	23	53	134	56	2.6
DN50	27	61	126	62	3.5

All dimensions in millimetres (mm). Flange dimensions vary according to specification (available upon request). Please note that DN32, DN65 & DN80 valves are not available in stainless steel.

SEAT TYPES - SPRING/PRESSURE RANGES

Seat Housing	Valve	Pressure Range	Temperature Range	Spring Ranges (bar & p.s.i.)			
				A (Low)	B (Medium)	C (High)	D (Special*)
316 St. Steel	316 St. Steel	to 20.7 bar (300 p.s.i.)	-60° to +350°C	0.5 - 3.5 (7 - 50)	3.5 - 10.4 (50 - 150)	10.4 - 20.7 (150 - 300)	N/A
316 St. Steel PTFE insert	316 St. Steel	to 20.7 bar (300 p.s.i.)	-40° to +225°C	0.5 - 2.0 (7 - 30)	2.0 - 8.3 (30 - 120)	8.3 - 17.9 (120 - 260)	17.9 - 20.7 (260 - 300)
316 St. Steel VITON seal	316 St. Steel	to 20.7 bar (300 p.s.i.)	-15° to +200°C	0.5 - 2.0 (7 - 30)	2.0 - 8.3 (30 - 120)	8.3 - 16.5 (120 - 240)	16.5 - 20.7 (240 - 300)

* D spring only available as standard for DN15, DN20, DN25 and DN40 soft seated valves.

† SILICON seal also available on request - available set pressures will be confirmed at time of order.



GUYSON INTERNATIONAL LIMITED

HOSE & COUPLINGS DIVISION

Southview Business Park, Guiseley, Leeds LS20 9PR Tel: 01943 870044 Fax: 01943 870066

e-mail: leeds@guyson.co.uk web: www.guyson.co.uk





Discharge Capacities for Stainless Steel Safety Relief Valves

SATURATED STEAM in KILOGRAMS PER HOUR

Set Pressure (Bar Gauge)	with 10% Accumulation					Set Pressure (Bar Gauge)	with 10% Accumulation				
	DN15	DN20	DN25	DN40	DN50		DN15	DN20	DN25	DN40	DN50
1	13	29	52	118	210	11	75	168	302	680	1212
2	19	43	76	172	304	12	81	182	326	733	1306
3	24	55	98	227	394	13	86	195	350	786	1400
4	31	69	123	283	494	14	92	209	374	873	1554
5	38	86	152	344	611	15	100	225	401	904	1611
6	44	100	178	400	714	16	107	241	429	966	1723
7	50	112	201	453	807	17	115	257	456	1029	1836
8	56	126	227	510	910	18	121	270	481	1084	1940
9	63	140	253	568	1013	19	126	284	505	1136	2040
10	70	155	278	625	1116	20	132	297	529	1190	2141

HOT WATER in KILOWATTS

Set Pressure (Bar Gauge)	with 10% Accumulation					Set Pressure (Bar Gauge)	with 10% Accumulation				
	DN15	DN20	DN25	DN40	DN50		DN15	DN20	DN25	DN40	DN50
1	8	18	33	74	132	11	47	105	189	426	760
2	12	27	48	108	191	12	51	114	204	459	818
3	15	34	61	142	247	13	54	122	219	493	877
4	19	43	77	177	310	14	58	131	234	547	974
5	24	54	95	216	383	15	63	141	251	567	1010
6	28	63	112	251	447	16	67	151	269	605	1080
7	31	70	126	284	506	17	72	161	286	645	1151
8	35	79	142	320	570	18	76	169	301	679	1216
9	39	88	159	356	635	19	79	178	316	712	1278
10	44	97	174	392	699	20	83	186	332	746	1342

WATER in LITRES PER MINUTE

Set Pressure (Bar Gauge)	with 10% Accumulation					Set Pressure (Bar Gauge)	with 10% Accumulation				
	DN15	DN20	DN25	DN40	DN50		DN15	DN20	DN25	DN40	DN50
1	6	15	26	60	109	11	20	47	84	190	332
2	8	20	35	81	145	12	21	49	88	199	334
3	10	23	42	96	172	13	22	51	92	208	336
4	12	27	49	111	201	14	23	53	96	217	344
5	14	31	56	128	230	15	24	55	100	225	374
6	15	34	61	140	253	16	25	57	103	233	404
7	16	37	66	151	273	17	26	59	106	241	434
8	17	40	71	161	291	18	26	61	110	248	449
9	18	42	75	171	308	19	27	63	113	255	461
10	19	44	80	180	326	20	28	65	116	262	473

FREE AIR in LITRES PER SECOND AT 20°C

Set Pressure (Bar Gauge)	with 10% Accumulation					Set Pressure (Bar Gauge)	with 10% Accumulation				
	DN15	DN20	DN25	DN40	DN50		DN15	DN20	DN25	DN40	DN50
1	5	11	18	43	78	11	28	63	111	254	452
2	7	16	27	62	113	12	31	68	121	274	486
3	9	21	36	75	146	13	33	73	130	294	520
4	12	26	45	102	183	14	36	78	138	315	556
5	15	32	55	126	225	15	38	84	149	338	598
6	17	36	65	149	267	16	40	90	160	360	640
7	18	42	73	168	302	17	43	95	170	384	682
8	21	47	83	190	340	18	45	100	178	404	718
9	23	53	92	212	378	19	48	105	187	424	753
10	26	58	102	234	417	20	50	110	196	443	788

Pressure Relief Valves

CONVERSION FIGURES

Steam.....	lbs/h	x	0.4535	=	kg/h
Hot Water...	Btu/h	x	0.0003	=	kW
Air	m ³ /h	x	16.667	=	L/min
	ft ³ /min	x	28.32	=	L/min
Water	m ³ /h	x	16.667	=	L/min
	gpm	x	4.546	=	L/min
Pressure	psi	x	0.069	=	bar. g.
	kg/cm ²	x	0.98	=	bar. g.
	in. Water	x	0.0025	=	bar. g.

Gresswell Valves have over 65 years experience in the manufacture of Safety and Relief Valves, supplying all industries worldwide and are approved to BS EN ISO 9001:2000 quality standards. (Certificate No. 0910407.)

The ranges include versions in both Bronze (leaflet Ref: G55 & G90) and Stainless Steel as well as a choice of seating arrangements to suit even the most demanding applications.

Designed to protect systems against overpressure, the G36 range has proven to be the ideal safety device for thousands of users.

- Only 4 Springs are needed to cover the range's working pressure of 0.5 to 20.7 Bar g.

- Screwed/Flanged connections or a combination of both available as standard.

- A variety of Seating arrangements are available - allows the best selection for the products being handled.

- All valves are supplied pre-set.

- Clear operating and maintenance instructions are supplied.

VALVE OPERATION

All our pressure relief valves are designed to function automatically. They are fitted to systems to prevent a safe pressure being exceeded. As protective devices they will perform reliably and will require the minimum of maintenance.

As 'proportional lift' type valves, the lift, and therefore the flow-rate, is determined by the amount of 'overpressure' within the system. The accepted point to measure this flow is when the predetermined pressure (the set pressure) is exceeded by 10% - the maximum pressure including 10% accumulation is shown on the flow-rate charts overleaf.

INSTALLATION

- 1) It is recommended that the G36 valve be sited with their spindles upwards at a point where pressure surging or pulsation does not occur.
- 2) If thread sealing is required, **DO NOT** use PTFE tape as small pieces can easily foul the valve seat and cause 'weeping'. Always use a liquid sealer instead.
- 3) Discharge pipes should not be smaller than the valves outlet port and **must** be self draining. If the installation forms part of a sealed system, any possible 'back pressure must be considered in the setting of the relief valve. Gresswell engineers are able to advise on this.
- 4) Valves should be positioned where there is no possible risk to personnel during the normal course of operation. Gresswell should be consulted if there is any doubt regarding the valves SAFE operation.

GRESSWELL VALVES strive to provide the best possible service and welcome any suggestions which would advance this process. Therefore we reserve the right to change specifications without prior notice. The company's engineering staff are able to assist in offering advice on further matters regarding the SAFE OPERATION of Safety and Relief valves. Information on sizing and selection can be obtained by contacting the GRESSWELL sales desk.

To place an order we request that you provide the following information regarding the intended service installation: OPERATING PRESSURE, OPERATING TEMPERATURE & INTENDED MEDIUM. Products selected and quoted for are based on the information provided and we reserve the right to amend / withdraw in part or in full should further information regarding the operating media and conditions (eg flow rates / viscosity etc) indicate that the products quoted may not be entirely suitable for the purpose(s) intended. Where a PED category is stated by Gresswell Valves, the product can only be used for the stated category.



GUYSON INTERNATIONAL LIMITED

HOSE & COUPLINGS DIVISION

Southview Business Park, Guiseley, Leeds LS20 9PR Tel: 01943 870044 Fax: 01943 870066
e-mail: leeds@guyson.co.uk web: www.guyson.co.uk

